

Project _____

Item # _____

Quantity _____



GLOBE FOOD EQUIPMENT COMPANY



CPSKB1



Soup Kettle

*Globe.
The ULTIMATE in
Countertop Equipment*

Model

- CPSKB1 Countertop Soup Kettle



Soup Kettle

CPSKB1

Standard Features

- Soup and sauce warmer (not a cooker)
- 10½ quart capacity
- Black powder-coated body
- Aluminum construction with fiberglass insulation
- Removable stainless steel insert
- Hinged, stainless steel and glass cover
- 400 watts, 120V for warming
- Control knob with 12 temperature settings
- Stable round base
- Comes with food labels
- 4½-foot power cord

Applications

- Soup and light sauce-type products in buffets, serving stations, prep areas, etc.
- Prepare product on range top and use soup kettle for serving and merchandising
- Increase your menu selection/sales by adding soup
- “Plug in and serve”

Standard Warranty

- Carry-in Warranty:
One-year parts and labor or replacement

Approved By: _____

Date: _____



GLOBE FOOD EQUIPMENT COMPANY

www.globeslicers.com

2153 Dryden Rd.
Dayton, OH 45439
Phone: 937-299-5493
Phone: 800-347-5423
Fax: 937-299-4147



Soup Kettle

CPSKB1

For Indoor Use Only

Electrical:

CPSKB1 - 120V, 400W, 3.5 amps

Cord and Plug: 4½-foot flexible, three-wire cord with ground plug (5-15P).

Standard Equipment: Standard equipment includes black powder-coated kettle with removable stainless steel insert, attached hinged cover, and 12 temperature settings.

Cookware

Suitable cookware includes :

Stainless steel insert only. Do not use other inserts, pots or pans in this unit.

Specifications

Capacity: 10.5 quarts

Multi Function Settings:

Heat: This function holds constant wattage for maintaining food, warm/hot, at a controlled temperature, 12 levels.

(12) Temperatures: This function controls cookware to a precise temperature for cooking, 12 different temperatures. This kettle is a warmer only, not a cooker.

DO NOT operate kettle without 2.5 cups of water in warming base.

Dimensions CPSKB1:

Foot Print = 13.1" x 14.2"
(33.3 cm x 36.1 cm)
Overall Length = 13.1" (33.3 cm)
Overall Width = 12.4" (31.5 cm)
Overall Height = 14.2" (36.1 cm)

Diameter = 13.1" (33.3 cm) round

Shipping Information:

Net Weight: 10 lbs (4.5 kg)

Shipping Weight: 13.5 lbs (6.2 kg)

Shipping Dimensions:

14"W x 16.4"D x 14.5"H
(35.5 cm x 41.5 cm x 35.5 cm)

Cartons are reinforced for shipping. The weight and dimensions of this reinforced carton are included above and may vary from shipment to shipment.

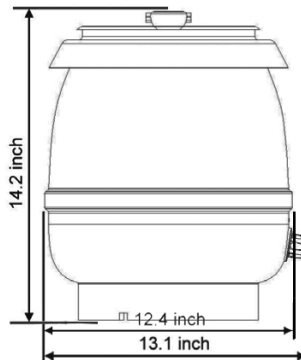

GLOBE FOOD EQUIPMENT COMPANY

www.globeslicers.com

2153 Dryden Rd.
Dayton, OH 45439
Phone: 937-299-5493
Phone: 800-347-5423
Fax: 937-299-4147

Printed in U.S.A. 08-2010

Specifications are subject to change without notice.