

PROJECT NAME: _____ LOCATION: _____

ITEM: _____ MODEL: _____



AHL-500
Food Warming Lamp

FEATURES LIST

Model	UPC
AHL-500	814387010466

SPECIFICATIONS

Food Warming Lamp-500 Watt
R40 or BR40 250W Screw Type Head Bulbs
Includes two R40, 250W bulbs
Gross Weight: 7.8 lbs.
Net Weight: 4.75 lbs.
5 Adjustable Heights

STANDARD FEATURES

Electrical

Voltage: 120V
Hertz: 60Hz
Wattage: 500W
Cord Length: 70 in.

Models Available

Model: AHL-500

Warranty (USA)

One-year limited warranty



Specifications subject to change without notice

Approvals: ETL ANSI-UL 197 & UL ANSI/NSF 4 Sanitation

PLAN VIEW

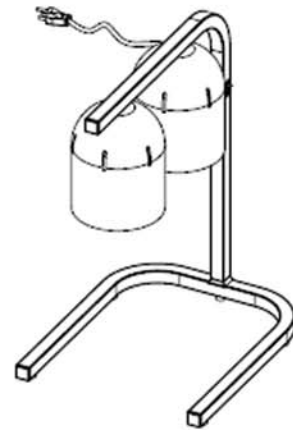
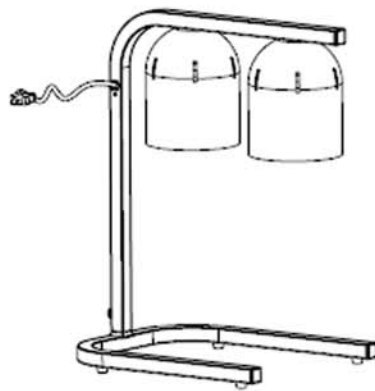
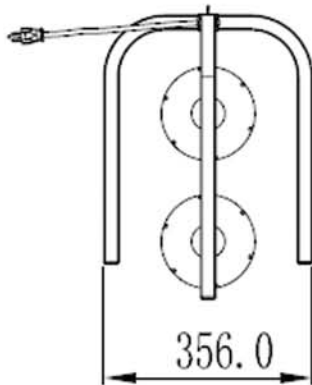
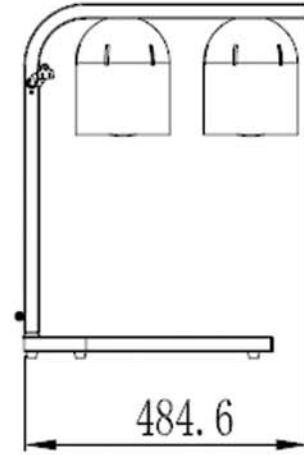
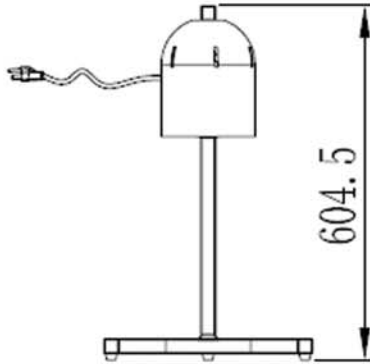

DIMENSIONAL DATA

Model	UPC	W x D x H	Voltage	Watts	Amps	Hertz	Weight	NEMA Plug	Cord Length
AHL-500	814387010466	21"x 22"x 14"	120V	500	4.16	60	7.8 lbs.	5-15P	70 in.