

PROJECT NAME: _____ LOCATION: _____

ITEM: _____ MODEL: _____



Model **CIM250**

250lb Ice Maker - Self Contained

The CIM250 is an extremely reliable and versatile ice maker that produces up to 260 pounds of ice per day and includes a self-contained 75 pound storage bin. Stainless steel construction provides durability to a unit that is low-maintenance and easy to clean. The unit produces crystal clear ice cubes that work great for applications in homes, restaurants, bars, hotels, grocery stores, and more. Front breathing unit, suitable for freestanding or built in applications, this unit will run on standard household electrical current and is NSF and UL approved for commercial use. The unit pairs high output and capacity with a self-contained, compact design.

FEATURE LIST

Model:	CIM250
Description:	250lb Ice Maker
Voltage:	120V/60Hz/1Ph, 220V/50Hz/1Ph
Ice Type:	Slab Cube
Ice Cube Size:	1" x 3/4" x 1" 25mm x 19mm x 25mm
Power Consumption:	9.4kWh / 100lbs of ice
Unit Weight:	144 lb / 65 kg
Unit Dimensions:	24" W x 24" D x 39" H 610mm W x 610mm D x 991mm H
Shipping Weight:	160 lb / 72.5 kg
Shipping Dimensions:	26" W x 26" D x 35" H 660mm W x 660mm D x 889mm H

Specifications subject to change without notice.

Approvals: NSF, UL, CE



PLAN VIEW

- Up to 260 lb (72.5 kg) daily ice production (based on 50/70° F)
- Produces crystal clear slab ice cubes
- Stainless steel exterior
- 75lb storage bin with automatic overflow prevention
- Easy to use automatic cleaning setting
- Front breathing air-cooled condenser
- Designed for household or commercial use
- For freestanding or built-in applications
- Requires use of a drain. Water filter recommended.

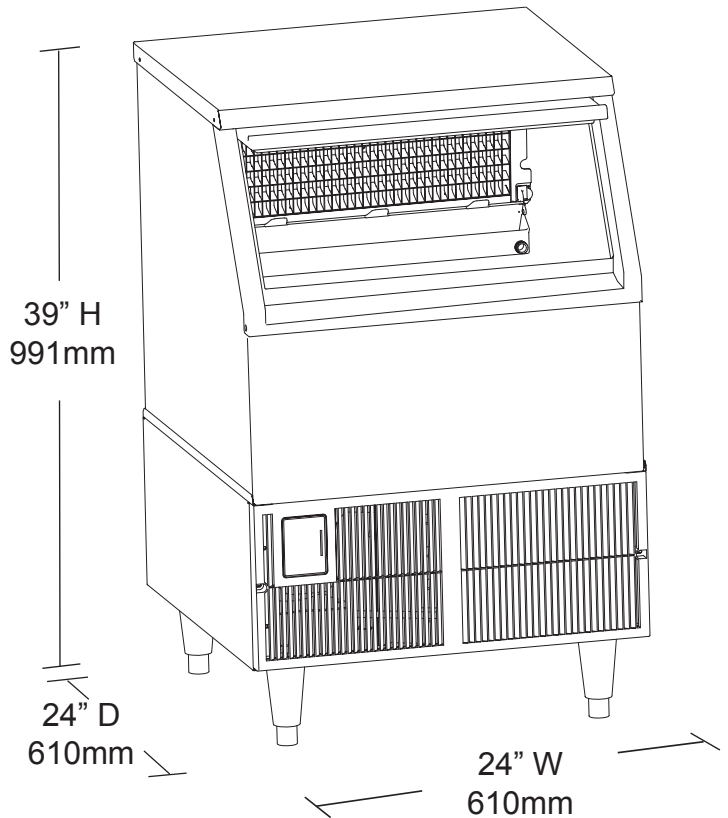

DIMENSIONAL DATA

Model	Description	Weight	Dimensions
CIM250	250lb Ice Maker	144 lb / 65 kg	24" W x 24" D x 39" H 610mm W x 610mm D x 991mm H